

KESSEL-Hybrid pumping station *Pumpfix F*

Installation in the concrete slab, from model year 01/2011

Backwater protection

1

Hybrid lifting stations

2

Lifting stations

3

Drains

4

Separators

5

Septic systems

6

Rainwater harvesting

7

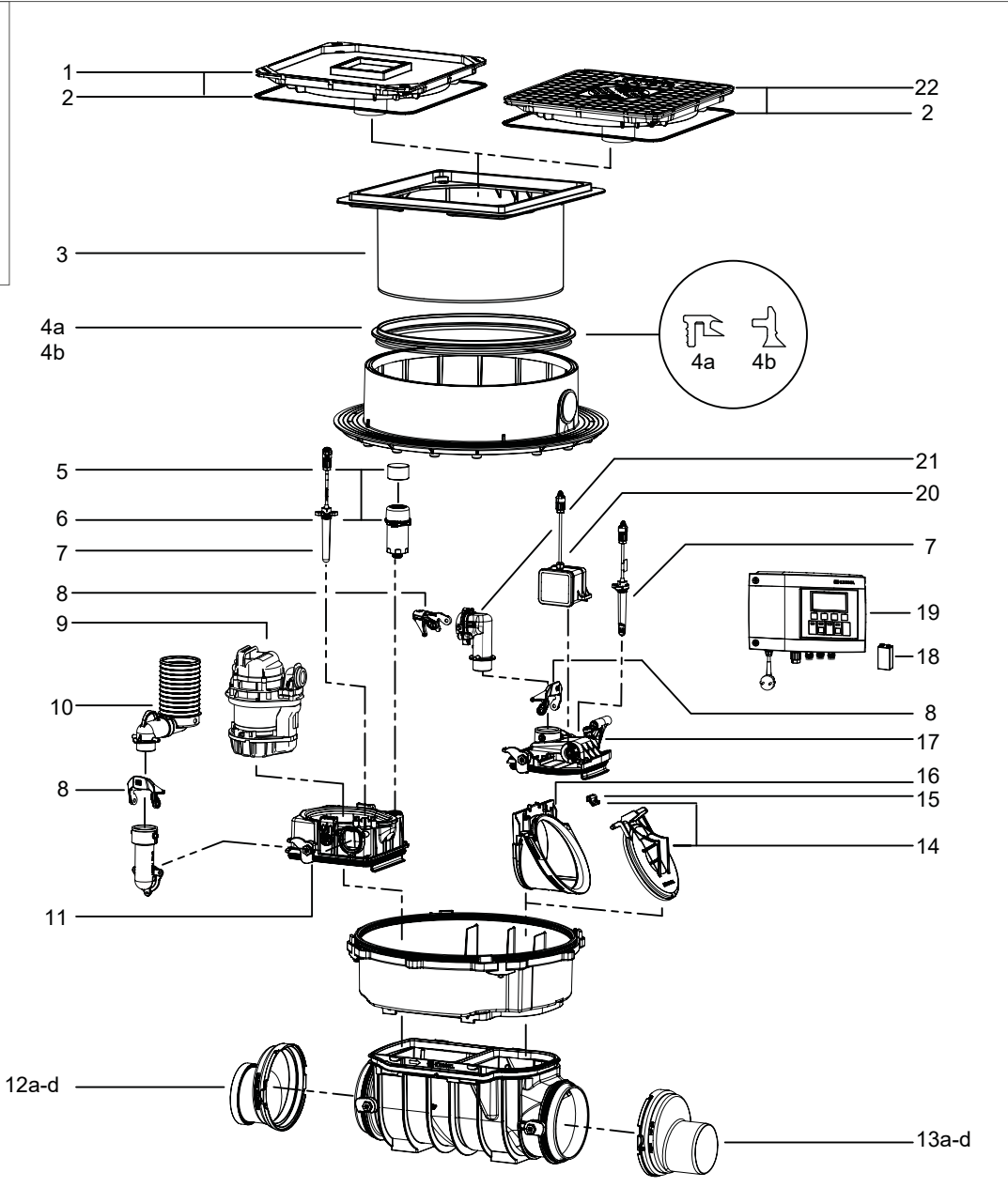
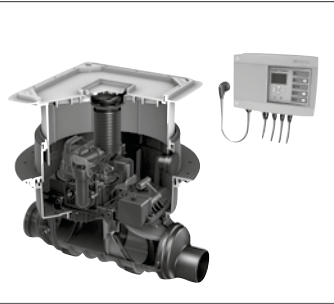

Pos.	Designation	Art. #
1	Cover plate stone grey, can be tiled over with drain and sealing gasket	83045
2	Sealing gasket for cover plate	680025
3	Upper section	83061
4	Profile lip seal	
4a	up to model year 06/2014	680026
4b	from model year 07/2014	680150
5	Activated carbon filter (5 x)	28061
6	Ventilation incl. activated carbon filter	28060
7	Optical probe with 3 adaptors	80888
8	Locking lever	680018
9	Pump complete with 5 m cable	28351
10	Inlet connection incl. sealing gasket	680075
11	Cover inlet side with drain	28054
12	Socket incl. sealing gasket	
12a	Ø 110	83085
12b	Ø 125	83086

Pos.	Designation	Art. #
12c	Ø 160	83087
12d	Ø 200	83088
13	Spigot incl. sealing gasket	
13a	Ø 110	83081
13b	Ø 125	83082
13c	Ø 160	83083
13d	Ø 200	83084
14	Motor-driven flap with flap stay	80038
15	Flap stay	680101
16	Insert flap housing for motor-driven flap with flap stay	80039
17	Cover outlet side	28056
18	Battery	680034
19	Control unit	28071
20	Drive motor complete with 5 m cable	80076
21	"Bypass" pump connection	680104
22	Cover plate black with drain and sealing gasket	83046
23	Sealing gasket set II	70319